

# Electronic Cruise Control for Can-Am Spyder SM5 & SE5



The following provides a brief description of the power consumption and component locations of the MotorCycle Setup electronic cruise control.

Installed weight of the cruise control is approximately 2.0kg.

Current draw while the cruise is switched on, but not engaged, is approximately 0.250 amp (3 watts). Current draw while the cruise is engaged is nominally 0.50~0.80 amp (6~10 Watts).

By comparison, a head light bulb typically draws about 4 amps (55 Watts), and a tail light bulb (running light) draws about 0.4 amp (5 Watts).

Refer to the line drawing on the back of this sheet to identify the components from the numbers in the text.

The **Computer (1)** mounts behind the head light on the frame, below the instrument cluster.



The **Actuator (2)** is bolted to the frame on the left side of the bike, to the left of the engine and slightly in front of the engine. A **vacuum hose assembly (3)** is provided to connect the actuator to the engine.



The **Cable Interface Unit (4)** is located above the front cylinder head on the engine. A new **cable (5)** connects it to the throttle bodies.



The **Speed sensor (6)** is mounted on the right side of the swing arm, on one of the inner fender mounting bolts. Nickel plated magnets are placed in the heads of the bolts that mount the ABS tone wheel.

On the SM5 (manual shift model) the **Control Switch (7M)** is mounted on the clutch lever mount, below the bike's switch gear.



On the SE5 (electric shift model) the **Control Switch (7E)** is mounted on the clamp for the paddle shift switch assembly. Approximately 1.5mm must be filed from the inside face of the clamp bracket for the shift switch to allow for the thickness of the cruise control switch bracket. This is clamp bracket NOT part of the shift switch, but a separate clamp to hold the switch mechanism to the handlebar.

The **Wiring Loom (9)** has the same type of plugs or terminals that are already used on the motorcycle. Power for the cruise control and brake sensing is taken off the brake light switches by unplugging the rear brake light switch. Matching connectors on the cruise control loom are plugged in to the switch and the bike's loom. Tach (engine speed) sensing is detected from the bike's ignition coils. This is used to disengage the cruise if the clutch is operated. The bike's clutch switch is also connected to the cruise control to disengage the cruise control (Manual shift model only). The cruise control is grounded on the negative battery terminal.

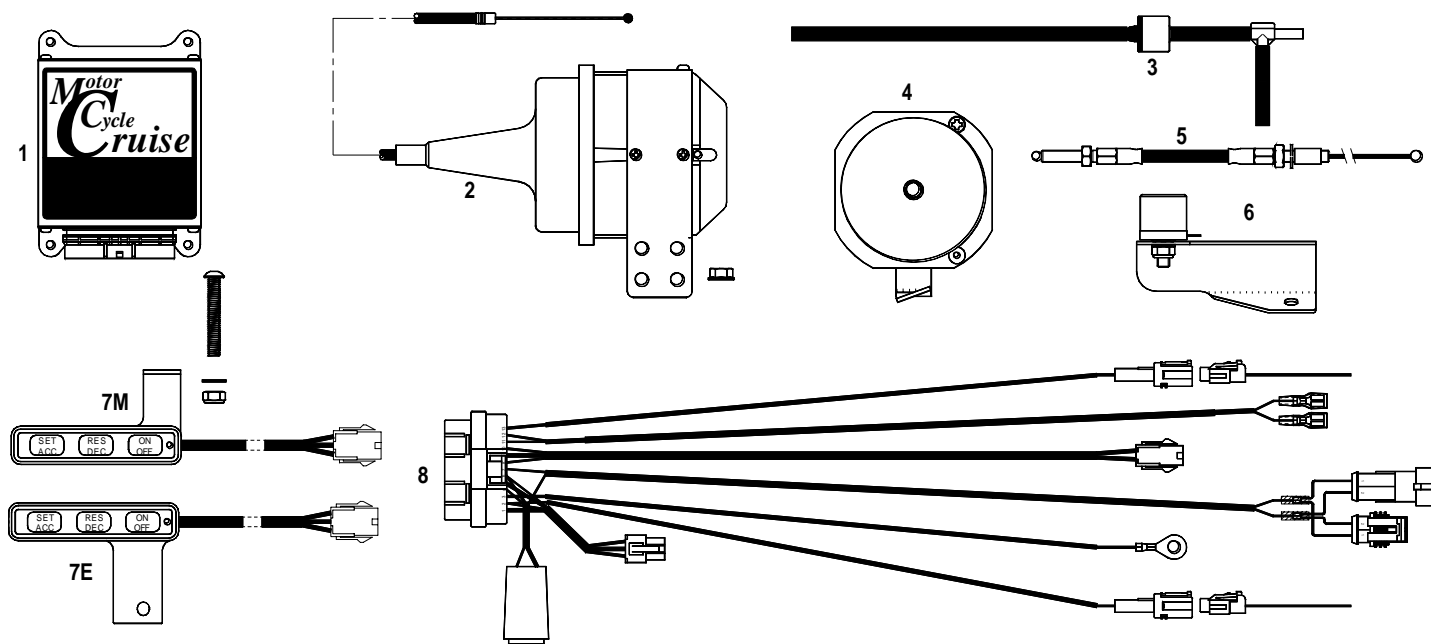

## *MotorCycle Cruise Controls*

6 Kingston Street  
Mount Waverley VIC 3149  
AUSTRALIA

Web Site:

<http://www.mccruise.com>

International:

Phone (International Access Code) 61 3 9808 2804

Fax (International Access Code) 61 3 9808 2445

Australia:

Phone (03) 9808 2804

Fax (03) 9808 2445

E-mail: [mccruise@optusnet.com.au](mailto:mccruise@optusnet.com.au)